

## **APPLICATIONS** **2003-2005 Cadillac CTS** **2004-2005 Cadillac SRX**

### **KIT FEATURES**

- DIN head unit provision with a pocket
- ISO DIN head unit provision with a pocket
- DDIN head unit provision
- Stacked ISO DIN head unit provision
- Stacked DIN head unit provision



### **KIT COMPONENTS**

A) Radio Housing | B) DDIN Brackets | C) DDIN Trim Plate | D) ISO Brackets | E) Trim Plate | F) (8) Phillips screws  
| (G) Pocket

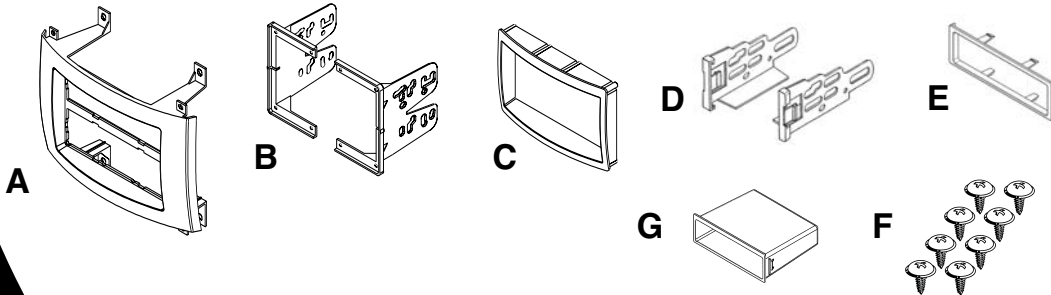

### **TOOLS REQUIRED:**

Phillips Screwdriver | Small Flat Blade Screwdriver | Socket Wrench

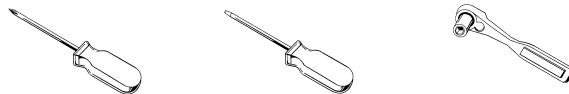

# **TABLE OF CONTENTS**

---

***Dash Disassembly* ..... 1**

***Kit Assembly* .....2, 3, 4**

***Final Assembly* ..... 5**

# **2003-2005 CADILLAC CTS** **2004-2005 CADILLAC SRX**

- 1** Disconnect the negative battery terminal to prevent an accidental short circuit.
- 2** Unclip and remove the center air vent assembly above the radio. (Figure A)
- 3** Unclip and remove the a/c control/ashtray assembly below the radio. (Figure B)
- 4** Remove (4) 10 MM screws securing the radio to the dash. (Figure C, D)

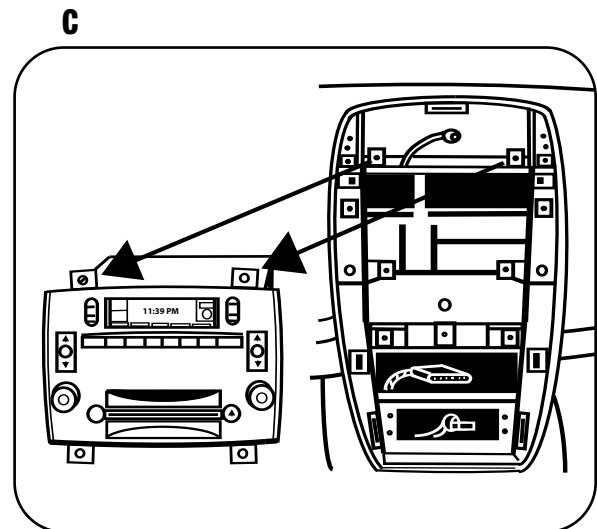
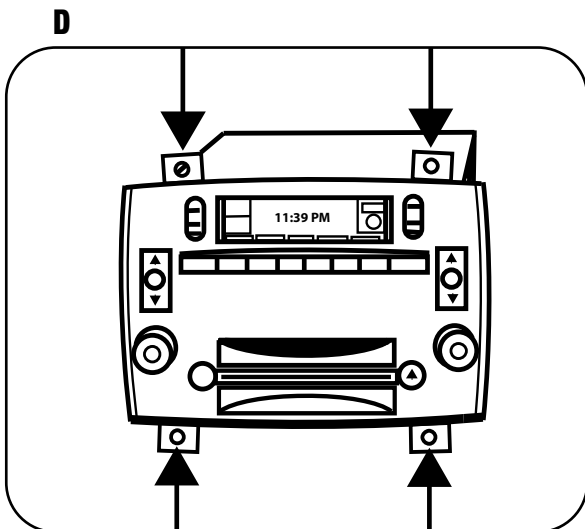
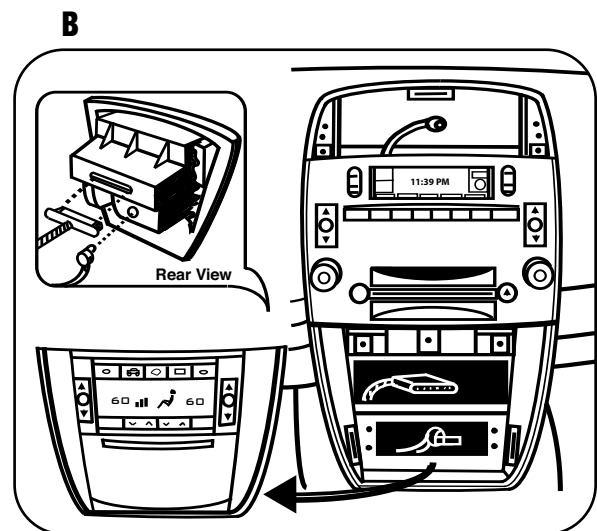
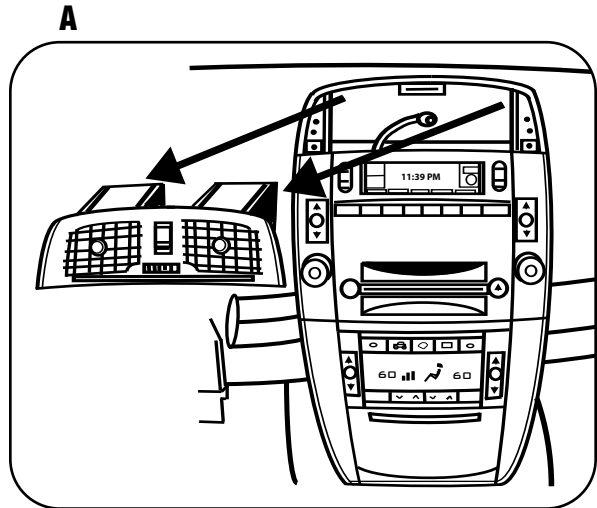

## DIN HEAD UNIT PROVISION

- 1** Slide the DIN cage into the Radio Housing and secure by bending the metal locking tabs down. (Figure A)
- 2** Slide the aftermarket head unit into the cage and secure. (Figure B)
- 3** Slide the supplied pocket into the unused opening.

**A**

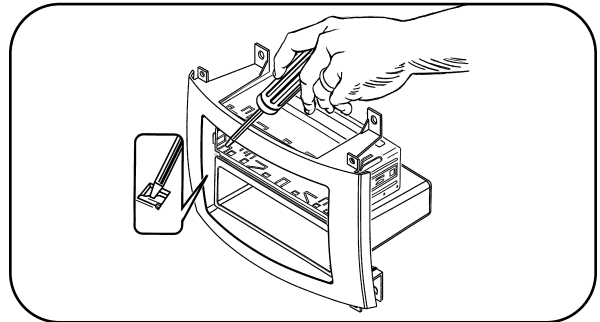

**B**

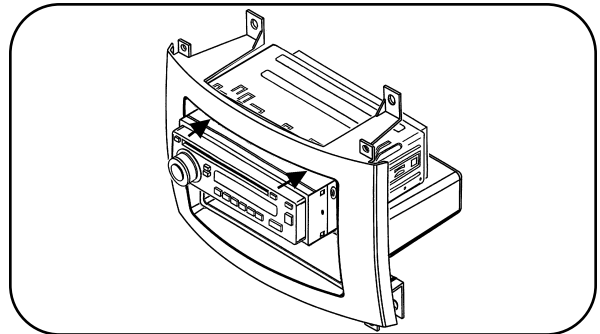

## ISO DIN HEAD UNIT PROVISION

- 1** Mount the ISO Brackets to the head unit with the screws supplied with the unit. (Figure A)
- 2** Slide the head unit into the radio opening until the side clips engage. (Figure B)
- 3** Snap the Trim plate into the Radio Housing. (Figure B)
- 4** Slide the supplied pocket into the unused opening.

**A**

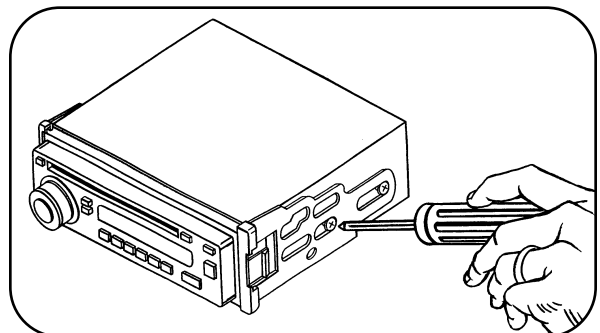

**B**

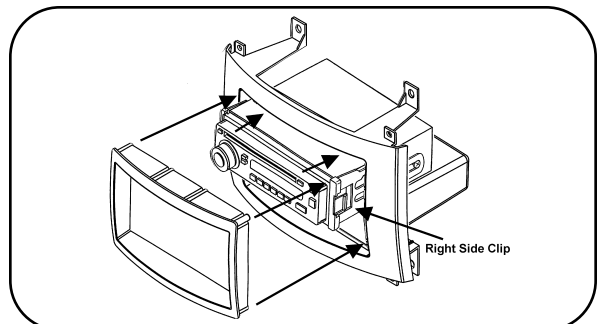

## DOUBLE DIN HEAD UNIT PROVISION

- 1 Remove the center bar from the 99-2006 radio housing. (Figure A)
- 2 Attach the corresponding bracket to the DDIN head unit. (Figure B)
- 3 Insert the DDIN trim plate into the radio housing. (Figure C)
- 4 Position the bracket/radio assembly to the back of the radio housing and secure with the (8) Phillips screws provided. (Figure D)

A

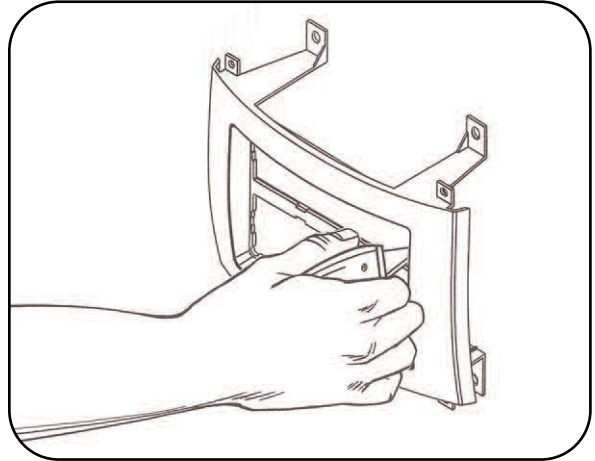

B

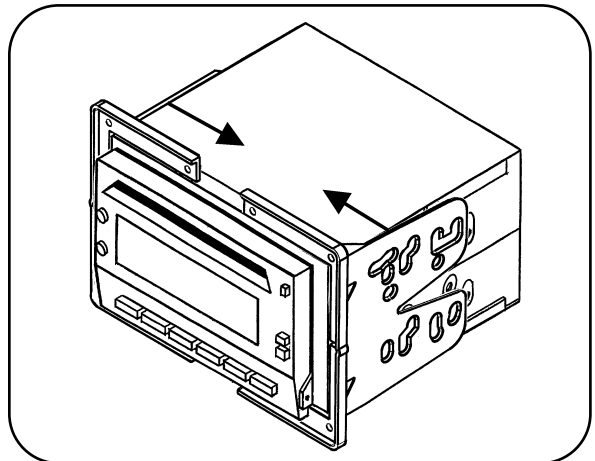

C

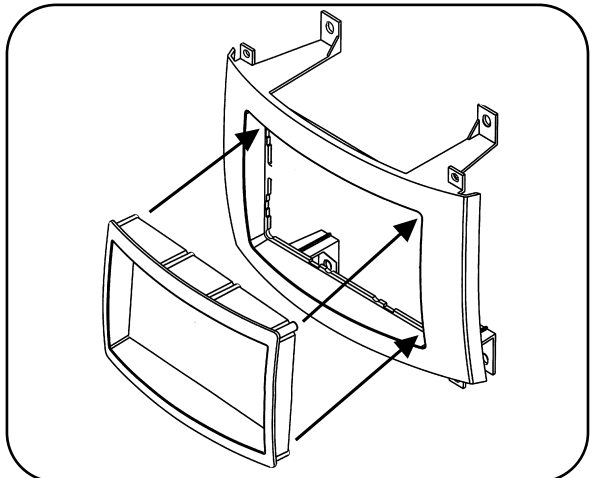

D

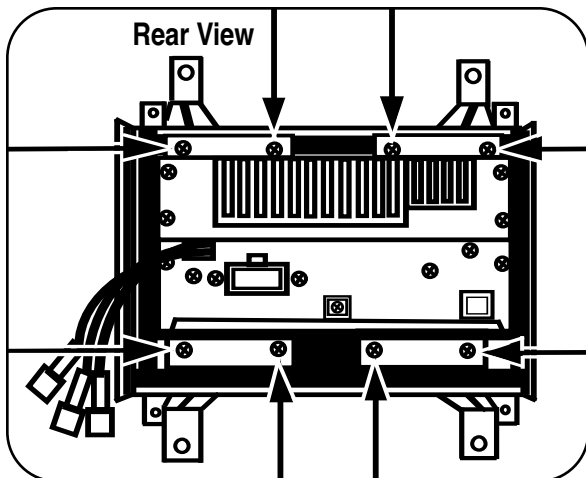

## **STACKED ISO DIN HEAD UNIT PROVISION**

- 1** Mount the ISO Brackets to the head units with the screws supplied with the unit. (Figure A)
- 2** Slide the head units into the radio openings until the side clips engage. (Figure B)
- 3** Snap the Trim plate into the Radio Housing. (Figure B)

**A**

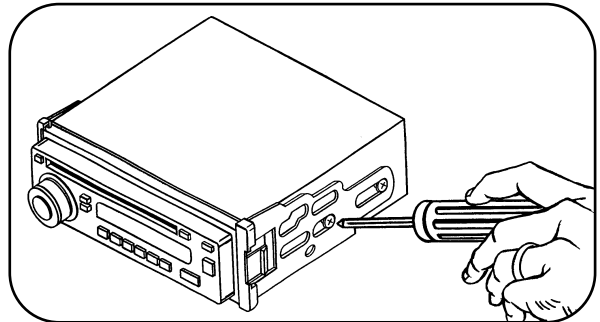

**B**

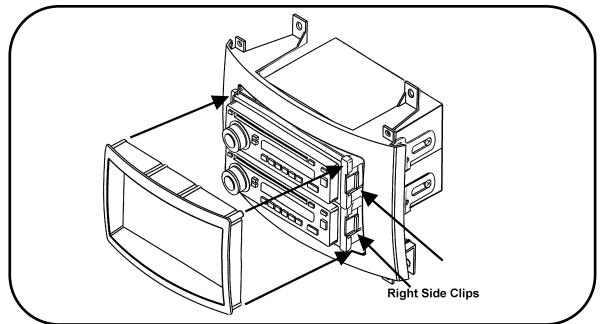

## **STACKED DIN HEAD UNIT PROVISION**

- 1** Slide the DIN cages into the Radio Housing and secure by bending the metal locking tabs outward. (Figure A)
- 2** Slide the aftermarket head units into the cages and secure. (Figure B)

**A**

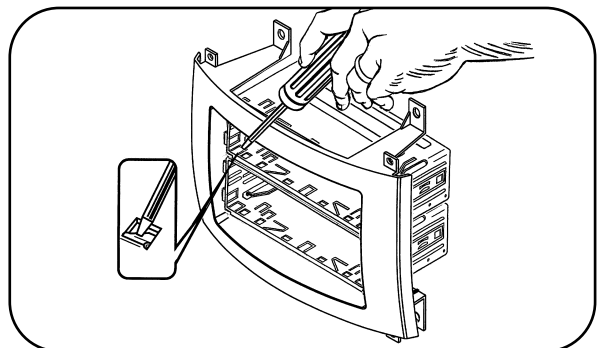

**B**

