

APPLICATIONS

FORD

2004-05 F-150 / 2005 Mustang
2005 Five-Hundred / 2005 Freestyle
2005 Mercury Montego

CAW-1114-53



KIT FEATURES

- Double DIN Head Unit Provisions
- Stacked ISO DIN Head Unit Provisions
- DIN Head Unit Provisions with Pocket
- ISO DIN Head Unit Provisions with Pocket

KIT COMPONENTS

A) Radio Housing (single DIN w/ pocket) | B) Radio Housing (double DIN / stacked ISO DIN)
C) Double DIN Brackets | D) ISO Brackets | E) Trim Plate

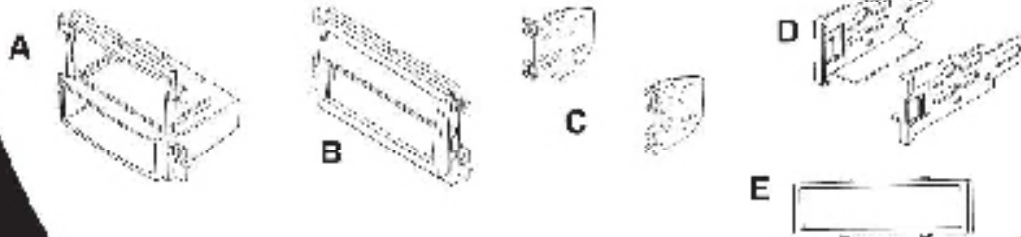

TOOLS REQUIRED:

Cutting Tool | Phillips Screwdriver | Socket Wrench



TABLE OF CONTENTS

Dash Disassembly

2004-05 Ford F-150.....	1
2005 Ford Mustang	2
2005 Ford Five Hundred / 2005 Mercury Montego.....	3
2005 Ford Freestar	4

Kit Assembly

DIN Head Unit Provision.....	5
ISO DIN Head Unit Provision	5
Double DIN Head Unit Provisions	6
Stacked ISO DIN Head Unit Provisions	7
Final Assembly	8
Notes	9

2004-2005 FORD F-150

- 1** Disconnect the negative battery terminal to prevent an accidental short circuit.
- 2** Unsnap and remove entire panel surrounding the radio and climate controls. (Figure A)
- 3** Remove (4) 9/32" screws to remove the factory radio. (Figure B)

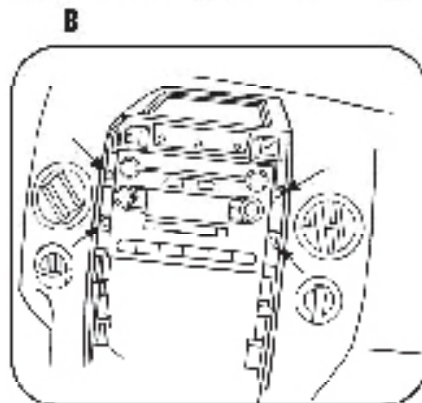
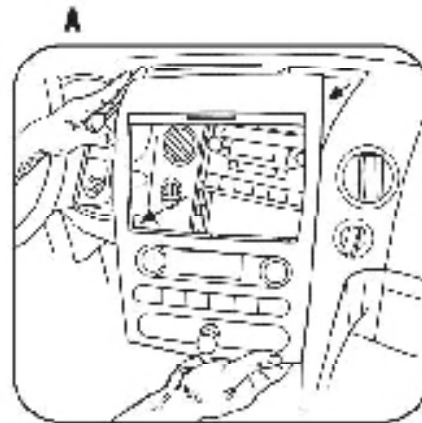

DASH DISASSEMBLY

2005 FORD MUSTANG

- 1 Disconnect the negative battery terminal to prevent an accidental short circuit.
- 2 Remove the small rectangular shifter lever trim panel if equipped. (Figure A)
- 3 Remove (2) Phillips screws from under the center armrest at the back of the shifter trim panel (including cup holders). (Figure B)
- 4 Unclip and remove panel. (Figure B)
- 5 Unclip and remove the (2) center stack trim panels from the left and right side of the radio and climate controls. (Figure C)
- 6 Remove (6) 9/32" screws from center trim panel surrounding the radio and climate controls then unclip and remove panel. (Figure D)
- 7 Remove (4) 9/32" screws from the radio to remove. (Figure E)

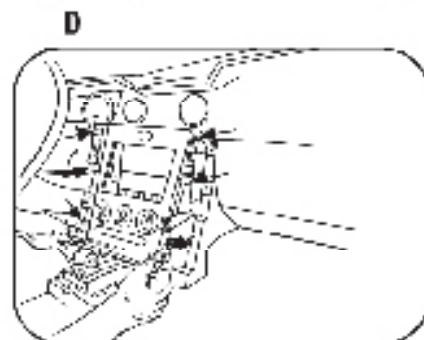
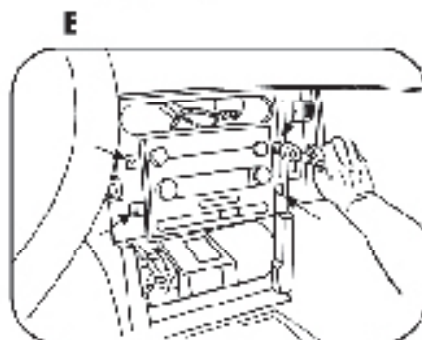
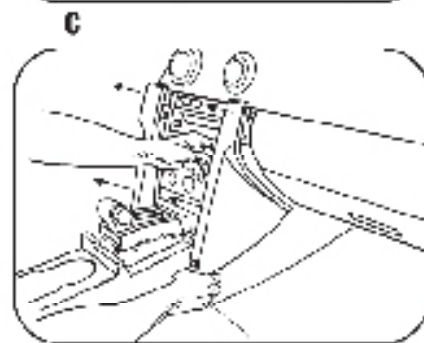
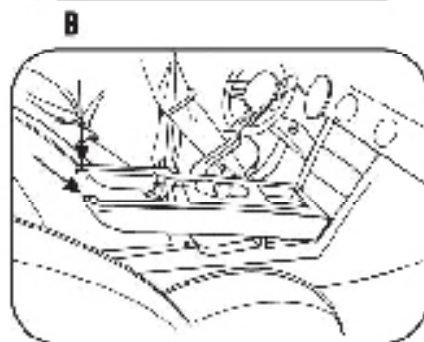
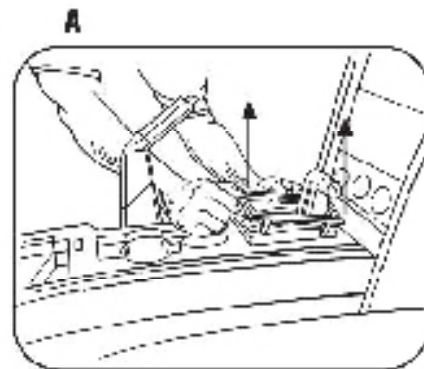

2005 FORD FIVE-HUNDRED

2005 MERCURY MONTEGO

- 1** Disconnect the negative battery terminal to prevent an accidental short circuit.
- 2** Unclip and remove the small rectangular trim around shift lever. (Figure A)
- 3** Unclip and remove the entire panel (including cup holders) surrounding the shift lever. (Figure B)
- 4** Remove (2) 9/32" screws at the bottom of the center radio/ climate control panel. (Figure C)
- 5** Unclip and remove the center panel. (Figure D)
- 6** Remove (4) 9/32" screws from the radio to remove. (Figure E)

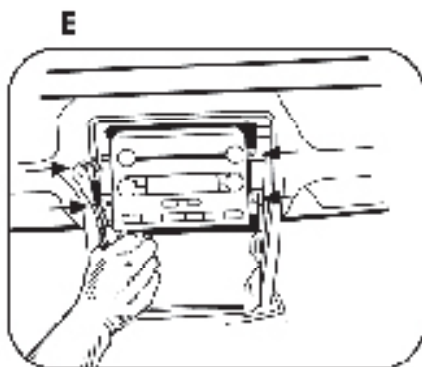
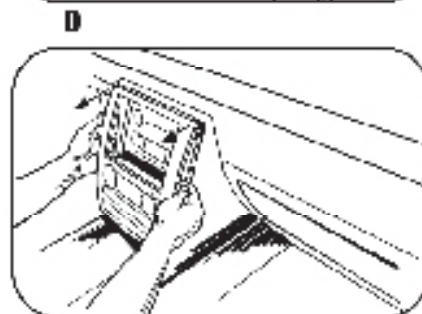
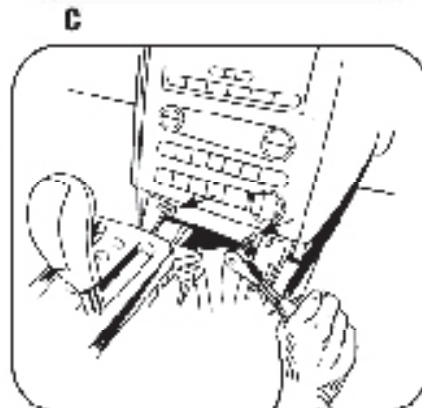
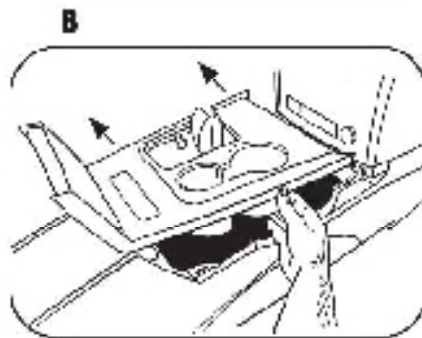
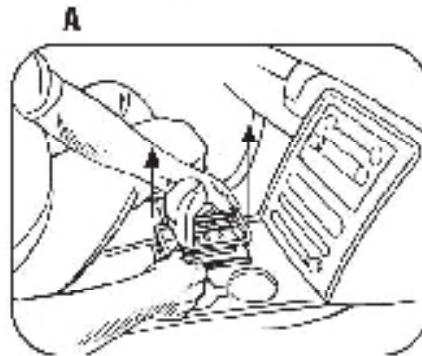

DASH DISASSEMBLY

2005 FORD FREESTAR

- 1 Disconnect the negative battery terminal to prevent an accidental short circuit.
- 2 Unclip and remove the entire center panel surrounding the radio and a/c controls. (Figure A)
- 3 Remove (4) 9/32" screws from radio to remove. (Figure B)

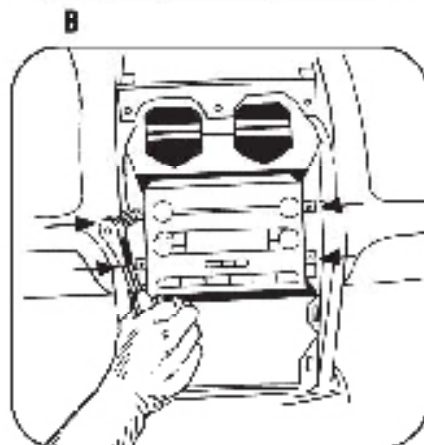
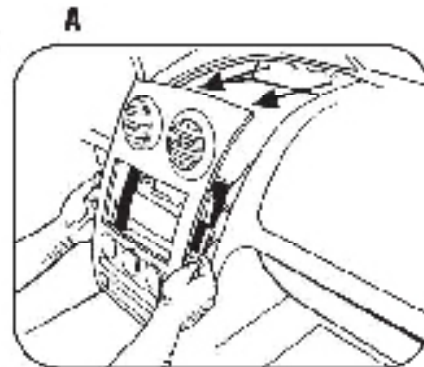

DIN HEAD UNIT PROVISION

- 1** Slide the DIN cage into the Radio Housing and secure by bending the metal locking tabs down. (Figure A)
- 2** Slide the aftermarket head unit into the cage and secure. (Figure B)

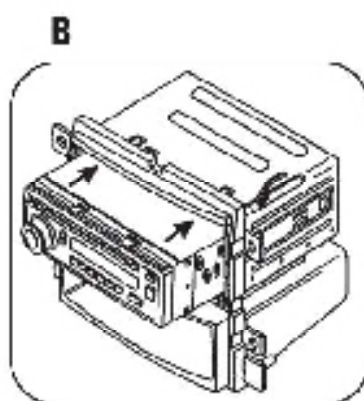
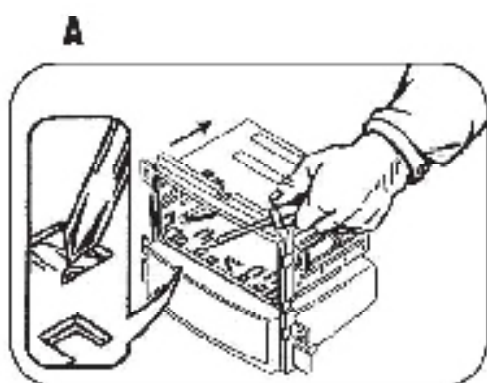

ISO DIN HEAD UNIT PROVISION

- 1** Mount the ISO Brackets to the head unit with the screws supplied with the unit. (Figure A)
- 2** Slide the head unit into the radio opening until the side clips engage. (Figure B)
- 3** Snap the Trim plate into the Radio Housing. (Figure B)

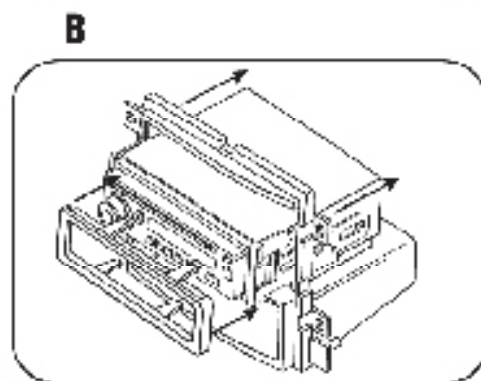
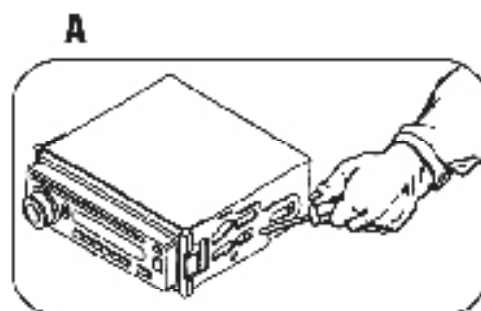

DOUBLE DIN HEAD UNIT PROVISION

- 1 Remove the center bar from the Double DIN trim plate (Figure A)
- 2 Slide the appropriate side bracket over the mounting legs of the Double DIN trim plate aligning the holes in the trim plate and the bracket. (Figure B)
- 3 Slide the DDIN radio unit into the trim plate bracket assembly and secure the unit to the kit using the screws supplied with the head unit. (Figure C)

NOTE:

The notch in the housing should be on top.

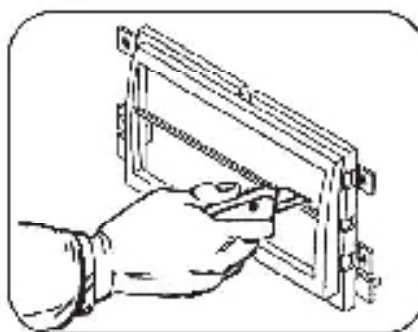
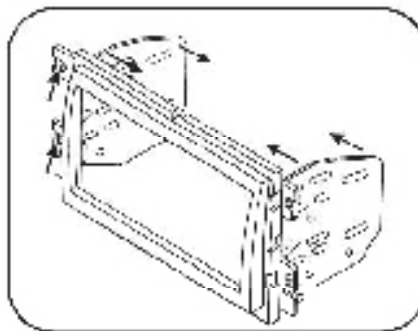
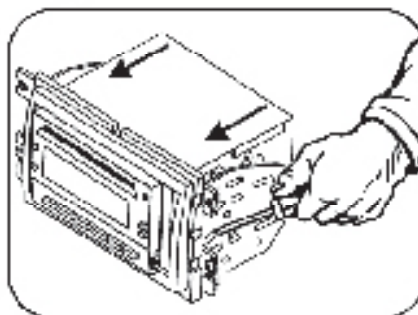
A**B****C**

STACKED ISO DIN HEAD UNIT PROVISION

- 1** Slide the appropriate side bracket over the mounting legs of the Double DIN trim plate aligning the holes in the trim plate and the bracket. (Figure A)
- 2** Slide the stacked ISO DIN units into the trim plate bracket assembly and secure the units to the kit using the screws supplied with the head units. (Figure B)

NOTE:

The notch in the housing should be on top.

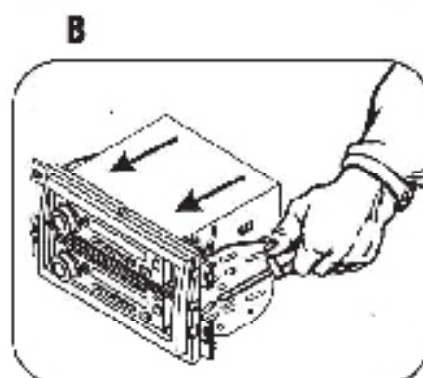
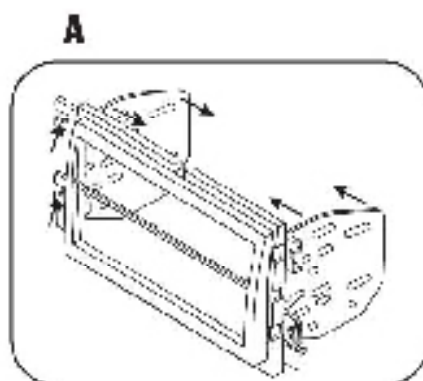

KIT ASSEMBLY