

2-DIN CAW-1170-07

APPLICATIONS

Mazda 3 2004-2007

Excluding 2007 models with automatic climate controls.



KIT FEATURES

- Double DIN Radio Provision
- Stacked ISO Mount Units Provision
- Bonus Display Replacement Pocket

KIT COMPONENTS

- A) Radio Housing • B) Double DIN Brackets • C) Double DIN Trim plate •
D) Display Replacement Pocket

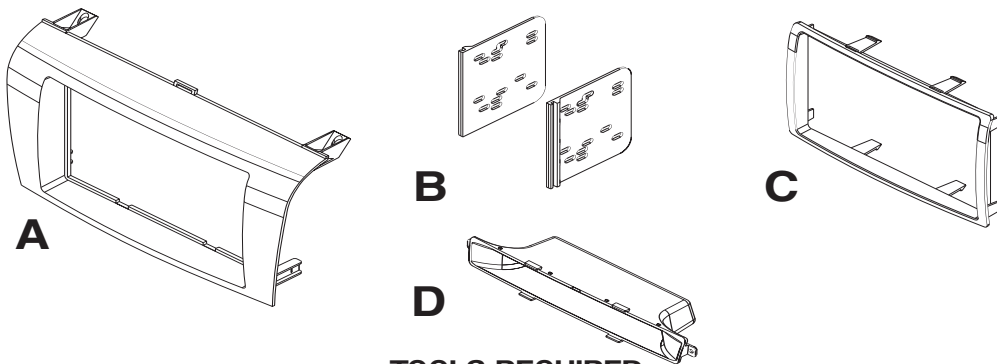

TOOLS REQUIRED:

- Small Flat Blade Screwdriver/ Panel Removal Tool
• Phillips Screwdriver



TABLE OF CONTENTS

Dash Disassembly

- Mazda 3 2004-2007	1
----------------------------------	----------

Kit Assembly

- Double DIN Radio Provision	2
---	----------

- Stacked ISO Units Provision	3
--	----------

<u>Final Assembly</u>	4,5
------------------------------------	------------

***Note:**

Refer also to the instructions included with the aftermarket radio.

1 Disconnect the negative battery terminal to prevent an accidental short circuit.

2 Unclip and remove display trim panel above radio. **Tip:** Open glove box and start in middle of panel working towards drivers side first because last connection on far passenger side is a hook. (Figure A)

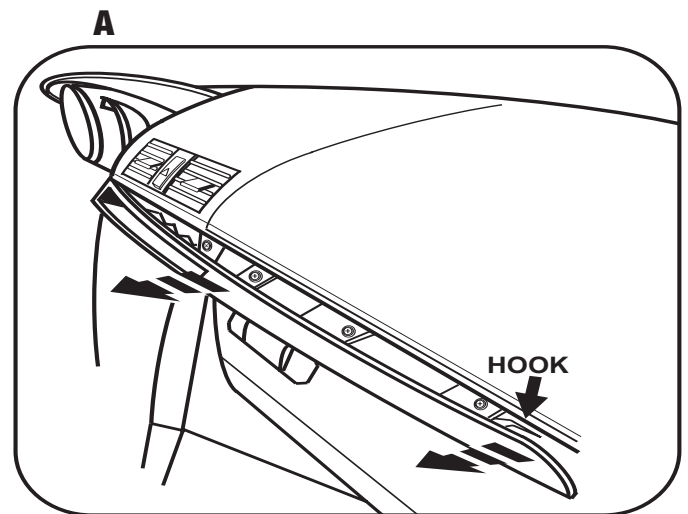

3 Remove (2) Phillips screws exposed at top of radio then unclip and remove radio. **Note:** *Display is attached to radio brackets and will be removed at same time as radio.* (Figure B)

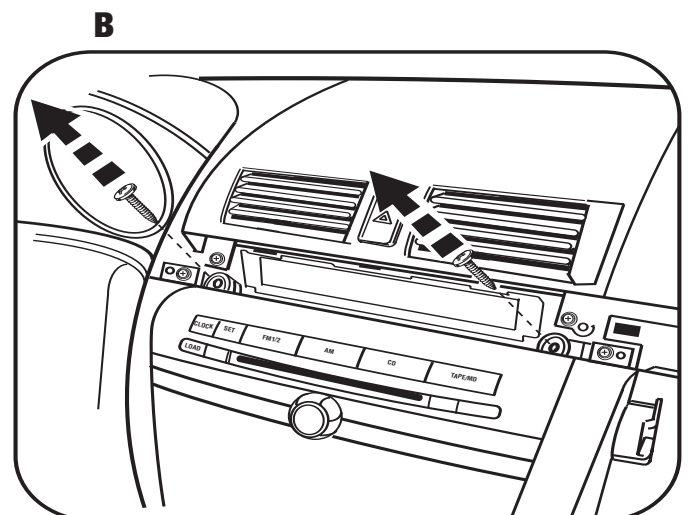

4 Remove (2) Phillips screws on back of display trim panel securing display trim then unclip and remove. (Figure C)

Continue to display pocket assembly.

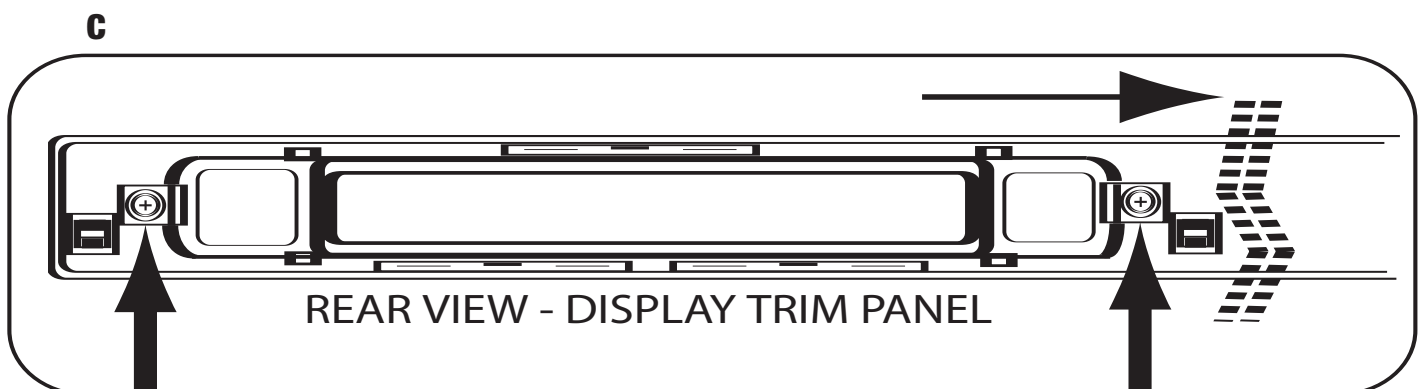

****Note: Refer also to the instructions included with the aftermarket radio.***

1 Using the (2) Phillips screws removed in step 4 of Dash Disassembly secure the display replacement pocket to the back of the display trim panel. (Figure A)

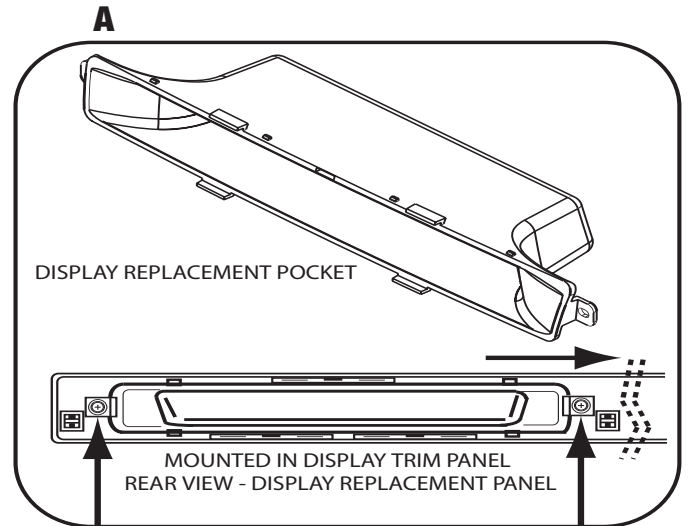

2 Snap the Double DIN brackets to the inside edge of the radio housing. (Figure B)

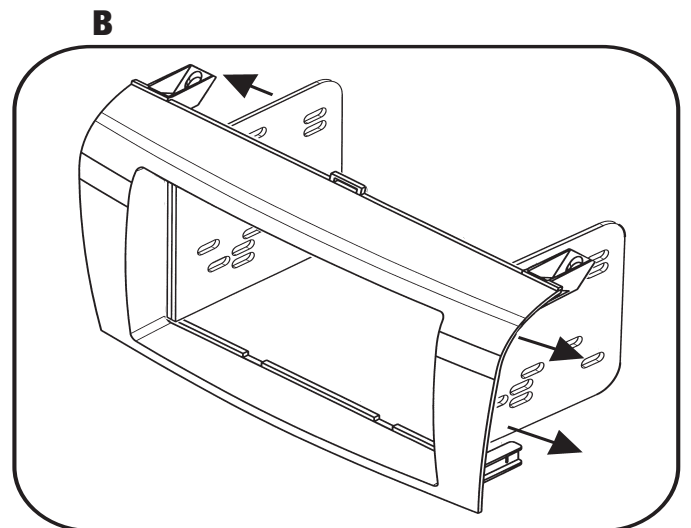

3 Slide the Double DIN radio into the bracket/radio housing assembly and secure the radio to the assembly using the screws supplied with the radio. Snap the trim plate onto the front of the radio housing. (Figure C)

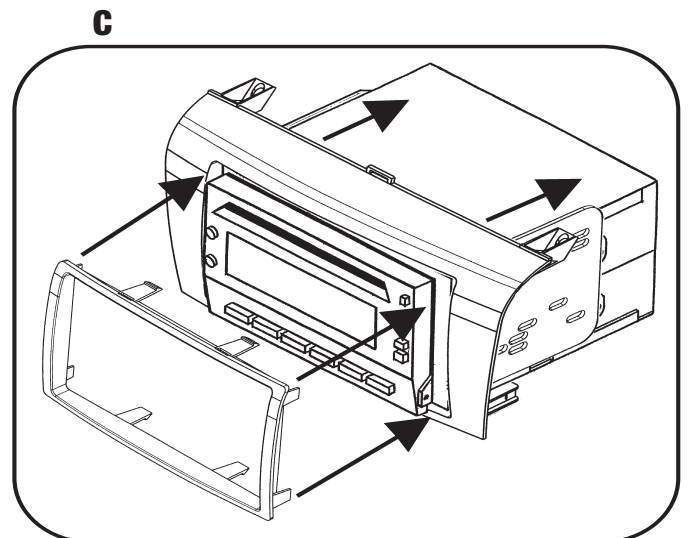

Continue to final assembly.

****Note: Refer also to the instructions included with the aftermarket radio.***

1 Using the (2) Phillips screws removed in step 4 of Dash Disassembly secure the display replacement pocket to the back of the display trim panel. (Figure A)

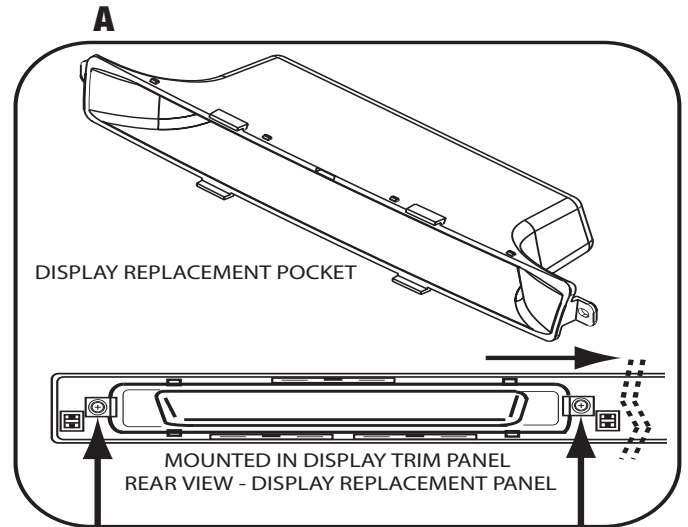

2 Snap the Double DIN brackets to the inside edge of the radio housing. (Figure B)

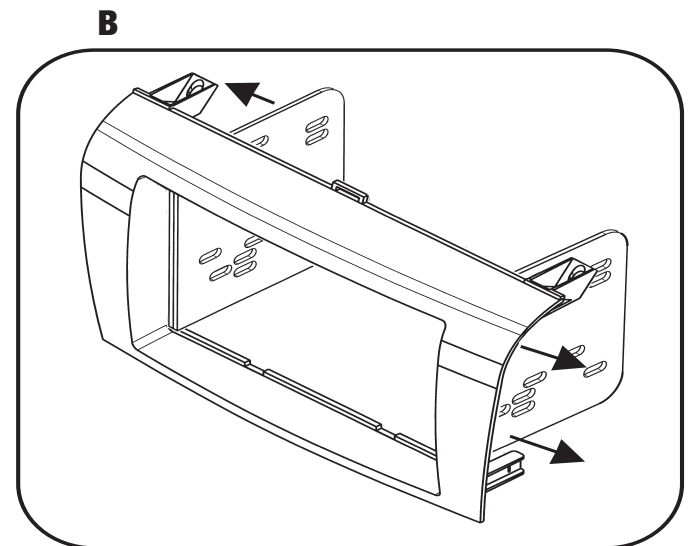

3 Slide the stacked ISO units into the bracket/radio housing assembly and secure the units to the kit using the screws supplied with the units. Snap the trim plate onto the front of the radio housing. (Figure C)

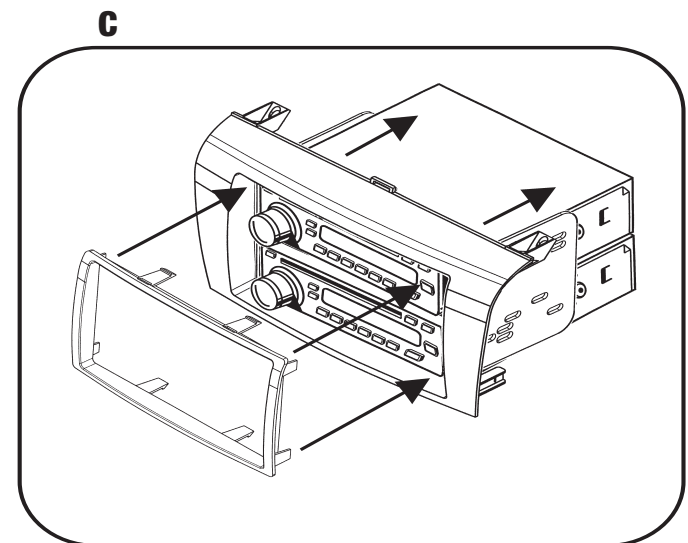

Continue to final assembly.